

## Advanced Assembly Design using Creo Parametric 3.0

### Overview

---

Course Code TRN-4503-T

Course Length 3 Days

In this course, you will learn how to use Creo Parametric 3.0 to create and manage complex assemblies. You will learn how to use advanced assembly tools that enable you to add and maintain designs, increase your efficiency, and increase system performance when working with large assemblies. In addition, you will learn the basics of using and creating predefined assembly structures and skeletons, which are both valuable tools typically used in a top-down design process. The course also includes an assembly design project that enables you to practice your new skills by performing various design tasks in an assembly model.

At the end of each module, you will complete a set of review questions to reinforce critical topics from that module. At the end of the course, you will complete a course assessment in Pro/FICIENCY intended to evaluate your understanding of the course as a whole.



### Course Objectives

---

- Use advanced component selection
- Use advanced assembly constraints
- Create and use component interfaces
- Utilize intelligent fasteners
- Create and use flexible components
- Restructure and mirror assemblies
- Use assembly features and shrinkwrap
- Replace components in an assembly
- Understand the basics of simplified reps
- Create cross-sections, display styles, and combined views
- Substitute components by reps, envelopes, and simplified reps
- Understand advanced simplified rep functionality
- Create and use assembly structure and skeletons
- Utilize design exploration

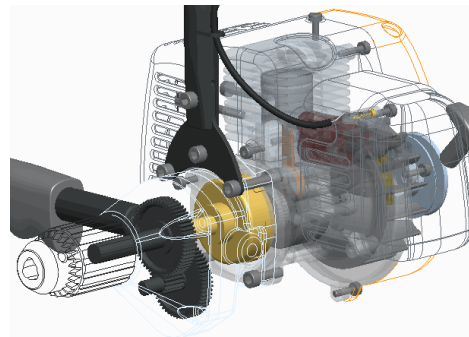

## Prerequisites

---

- Introduction to Creo Parametric 3.0
- Update to Creo Parametric 3.0 from Creo Parametric 2.0

## Audience

---

- This course is intended for design engineers and mechanical designers. People in related roles will also benefit from taking this course.
-

## Agenda

### Day 1

---

Module	1	Advanced Component Selection
Module	2	Using Advanced Assembly Constraints
Module	3	Creating and Using Component Interfaces
Module	4	Utilizing Intelligent Fasteners
Module	5	Creating and Using Flexible Components
Module	6	Restructuring and Mirroring Assemblies

### Day 2

---

Module	7	Using Assembly Features and Shrinkwrap
Module	8	Replacing Components in an Assembly
Module	9	Understanding the Basics of Simplified Reps
Module	10	Creating Cross-Sections, Display Styles, Layer States, and Combined Views

### Day 3

---

Module	11	Substituting Components using User Defined, Envelopes, and Simplified Reps
Module	12	Understanding Advanced Simplified Rep Functionality
Module	13	Creating and Using Assembly Structure and Skeletons
Module	14	Utilizing Design Exploration
Module	15	Project

---

## Course Content

### Module 1. Advanced Component Selection

- i. Locating Components in the Model Tree
- ii. Using the Assembly Model Tree Search Field
- iii. Selecting Multiple Components

*Knowledge Check Questions*

### Module 2. Using Advanced Assembly Constraints

- i. Constraining Components using Fix
- ii. Constraining Two Coordinate Systems
- iii. Constraining a Point on a Line
- iv. Constraining a Point on a Surface
- v. Constraining an Edge on a Surface
- vi. Constraining a Point on a Point
- vii. Creating a Tangent Constraint
- viii. Configuring Constraint Sets with Parameters

*Knowledge Check Questions*

### Module 3. Creating and Using Component Interfaces

- i. Understanding Component Interfaces
- ii. Using a Placing Component Interface
- iii. Using a Receiving Component Interface
- iv. Creating a Component Interface using the Save as Interface Dialog Box
- v. Auto Placing Components
- vi. Copying and Pasting Components
- vii. Repeating Component Placement

*Knowledge Check Questions*

### Module 4. Utilizing Intelligent Fasteners

- i. Understanding the Intelligent Fastener Extension
- ii. Assembling Intelligent Fasteners
- iii. Manipulating Intelligent Fasteners
- iv. Assembling Intelligent Fasteners Using Advanced Options
- v. Manipulating Intelligent Fasteners Using Advanced Options

*Knowledge Check Questions*

### Module 5. Creating and Using Flexible Components

- i. Adding Flexibility to a Component
- ii. Placing Flexible Components in an Assembly
- iii. Adding Flexibility to Already Placed Components
- iv. Using Flexible Parameters

*Knowledge Check Questions*

### Module 6. Restructuring and Mirroring Assemblies

---

- i. Restructuring and Reordering Assembly Components
- ii. Creating Mirrored Assemblies
- iii. Creating Mirrored Components
- iv. Creating Mirrored Sub-Assemblies

*Knowledge Check Questions*

#### **Module 7. Using Assembly Features and Shrinkwrap**

- i. Understanding Assembly Features
- ii. Understanding Assembly Feature Intersections
- iii. Creating an Assembly Cut
- iv. Creating Assembly Holes
- v. Creating a Shrinkwrap Feature
- vi. Creating a Shrinkwrap Model
- vii. Summarizing Shrinkwrap Features and Models

*Knowledge Check Questions*

#### **Module 8. Replacing Components in an Assembly**

- i. Understanding Component Replace
- ii. Replacing Components using Family Table
- iii. Replacing Components using Reference Model
- iv. Replacing Components using By Copy
- v. Replacing Unrelated Components
- vi. Understanding Interchange Assemblies
- vii. Replacing using a Functional Interchange Assembly

*Knowledge Check Questions*

#### **Module 9. Understanding the Basics of Simplified Reps**

- i. Retrieving Assembly Subsets
- ii. Understanding Standard Simplified Reps
- iii. Understanding Custom Simplified Reps
- iv. Lightweight Graphics Representations
- v. Using Graphics Simplified Reps
- vi. Using Geometry Simplified Reps
- vii. Excluding Components using Simplified Reps
- viii. Defining Simplified Reps Using the Component Chooser
- ix. Creating a Default Envelope Simplified Rep
- x. Creating Part Simplified Reps
- xi. Opening Simplified Reps

*Knowledge Check Questions*

#### **Module 10. Creating Cross-Sections, Display Styles, Layer States, and Combined Views**

- i. Understanding Assembly Cross-Sections
  - ii. Creating Assembly Cross-Sections
  - iii. Creating Offset Assembly Cross-Sections
-

- iv. Creating Zone Assembly Cross-Sections
- v. Creating Display Styles
- vi. Creating Layer States in an Assembly
- vii. Creating Combination Views

*Knowledge Check Questions*

**Module 11. Substituting Components using User Defined, Envelopes, and Simplified Reps**

- i. Understanding Envelopes
- ii. Creating and using a Surface Subset Shrinkwrap Envelope
- iii. Creating and Using a Faceted Shrinkwrap Envelope
- iv. Creating and Using an All Solid Surfaces Shrinkwrap Envelope
- v. Creating and Using a Create Features Envelope
- vi. Creating and Using an Envelope Copied from an Existing Part
- vii. Substituting Components using User Defined
- viii. Substituting by Interchange and Family Table

*Knowledge Check Questions*

**Module 12. Understanding Advanced Simplified Rep Functionality**

- i. Searching for Components for Simplified Reps
- ii. Creating Simplified Reps by Size
- iii. Creating Simplified Reps using Zones
- iv. Creating Simplified Reps by Distance
- v. Creating Simplified Reps using Exterior Components
- vi. Defining Simplified Reps using Rules
- vii. Using On-Demand Simplified Reps
- viii. Creating External Simplified Reps

*Knowledge Check Questions*

**Module 13. Creating and Using Assembly Structure and Skeletons**

- i. Understanding Skeletons
- ii. Creating an Assembly Structure
- iii. Creating Skeletons for Space Claims
- iv. Creating Skeletons for Placement References
- v. Copying a Model to a Skeleton
- vi. Creating Multiple Skeletons
- vii. Sharing Skeleton Geometry
- viii. Creating and Placing Models using Skeleton References
- ix. Creating a Motion Skeleton
- x. Sketching a Motion Skeleton
- xi. Creating Bodies for a Motion Skeleton
- xii. Assigning Connections for a Motion Skeleton
- xiii. Creating Solid Models from a Motion Skeleton

*Knowledge Check Questions*

---

**Module 14. Utilizing Design Exploration**

- i. Understanding Design Exploration
- ii. Exploring Part and Assembly Designs
- iii. Creating Design Exploration Branches
- iv. Opening and Saving Design Exploration Sessions
- v. Using Design Exploration Options
- vi. Utilizing Update Control with Copy Geometry Features

*Knowledge Check Questions*

**Module 15. Project**

- i. The Table Fan
- ii. Skeleton Models
- iii. The Shaft and Arm Parts
- iv. Components to Assemblies
- v. Editing the Design

*Knowledge Check Questions*

---